

- A1 FUEL CONNECTION INLET. 10mm I.D. HOSE
- A2 FUEL CONNECTION OUTLET. 10mm I.D. HOSE
- A3 FUEL FILTER/WATER SEPARATOR
- B1 OIL FILLER ENGINE
- B2 OIL FILTER, MAIN
- B3 OIL FILTER, BYPASS
- B4 OIL DIPSTICK ENGINE PORT STANDARD. CAN BE MOVED TO STARBOARD
- B5 OUTLET FOR OIL BILGE PUMP. 12mm/1/2" I.D. HOSE.
- B6 CRANK CASE VENTILATION FILTER
- C1 FRESH WATER FILLER
- C2 FRESH WATER DRAIN POINT
- C3 CONNECTION HDT WATER INLET R 1/2" (OPTION)
- C4 CONNECTION HDT WATER OUTLET R 1/2" (OPTION)
- D1 SEA WATER INLET FOR n 50 /2" I.D. HOSE.
- D2 SEA WATER DRAIN POINT (2x)
- D3 SEA WATER PUMP
- D4 WET EXHAUST CONNECTION. 127 mm / 5" I.D. HOSE
- D5 EXHAUST RISER (OPTION)
- E1 ECU CONTROL UNIT
- E2 ENGINE STOP
- E3 AUTOFUSES, ONLY 24V
- E4 DIAGNOSE CONNECTOR
- E5 DATALINK, SENDER AND AUX (2x)
- F1 AIR FILTER
- G1 ELASTIC SUSPENSION (4x). (OPTION)
- G2 LIFTING EYE, FRONT, n 40
- G3 LIFTING EYE, REAR, n 30
- J1 POWER STEERING PUMP ALT. EXTRA ALTERNATOR (OPTION)
- K1 CENTRE OF GRAVITY

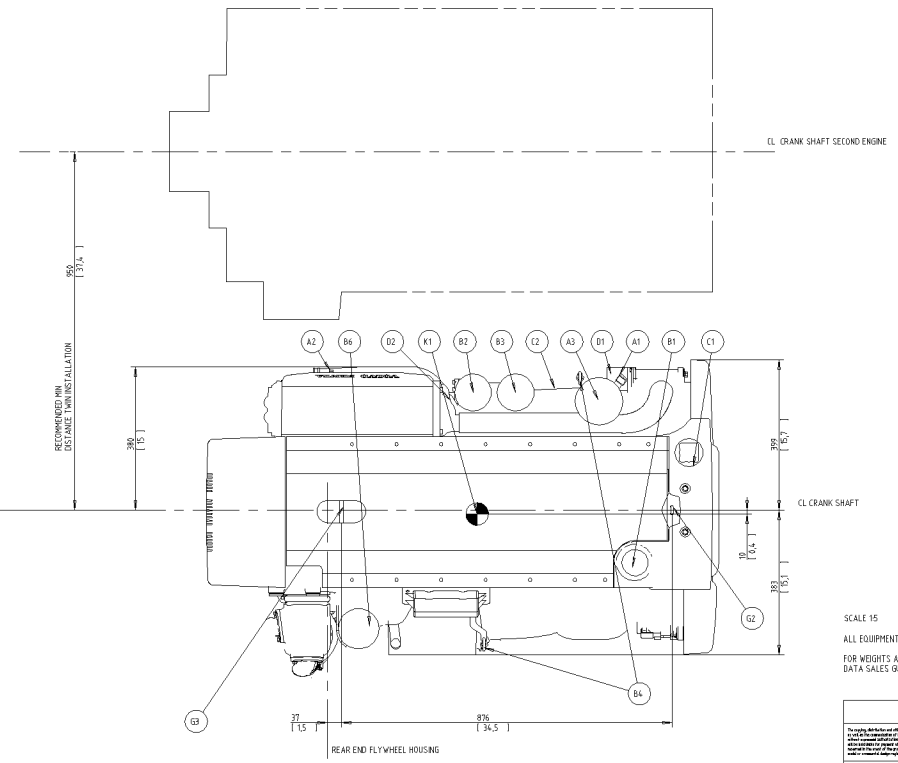
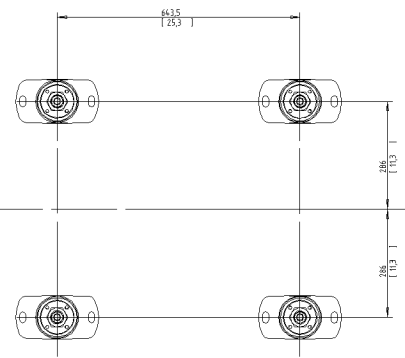
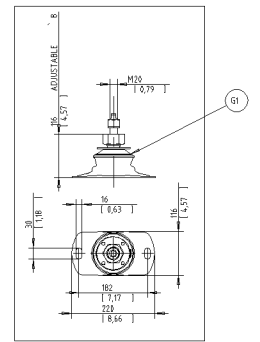

SCALE 1:5  
 ALL EQUIPMENT ON THE DRAWING IS NOT STANDARD  
 FOR WEIGHTS AND VOLUMES PLEASE REFER TO TECHNICAL DATA SALES GUIDE

	ENGINE DIMENSIONS P6-625-6T
	DIMENSION DRAWING
	21912430
	01